

LESSON 7

Loads and Boundary Conditions on a 3-D Clevis

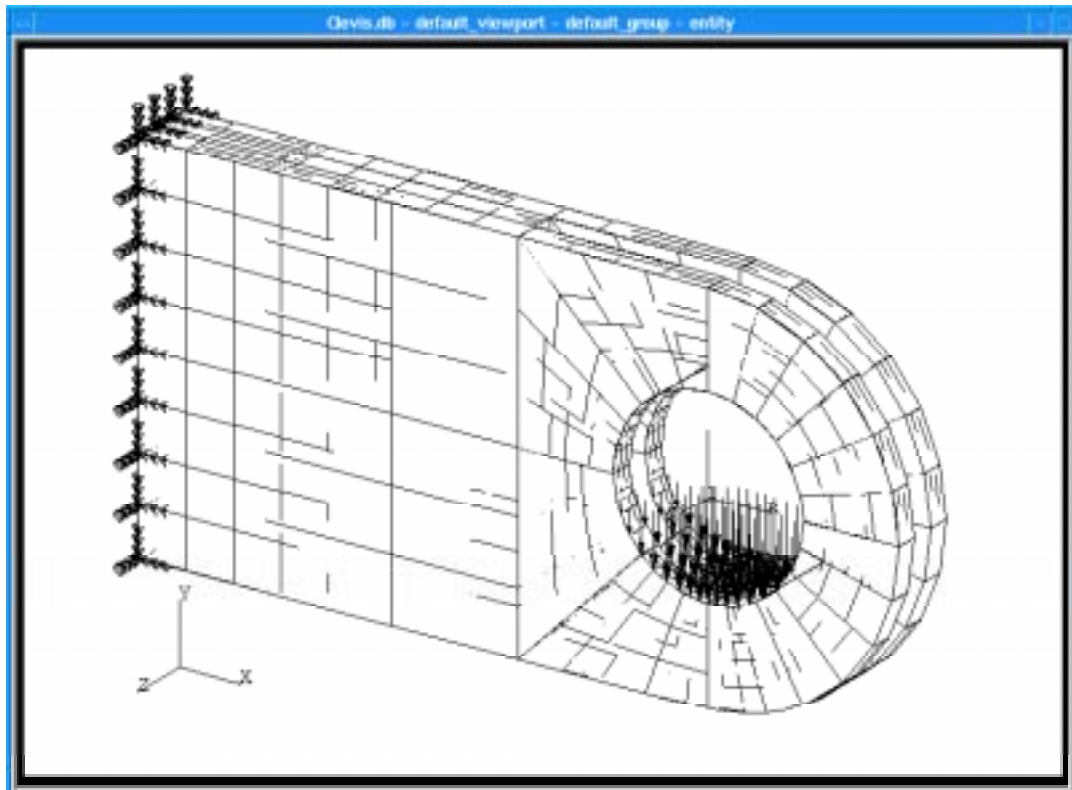

Objectives:

- Apply constraints to your model.
- Create and apply a **Field** to describe a spatially varying load.



Model Description:

In this exercise you will create a loading condition and a constraint set for the clevis model. The base of the lug will be clamped. The hole will be loaded downward with a quadratically varying load $F_y = -100(1-x^2)$ generated from a vector field.

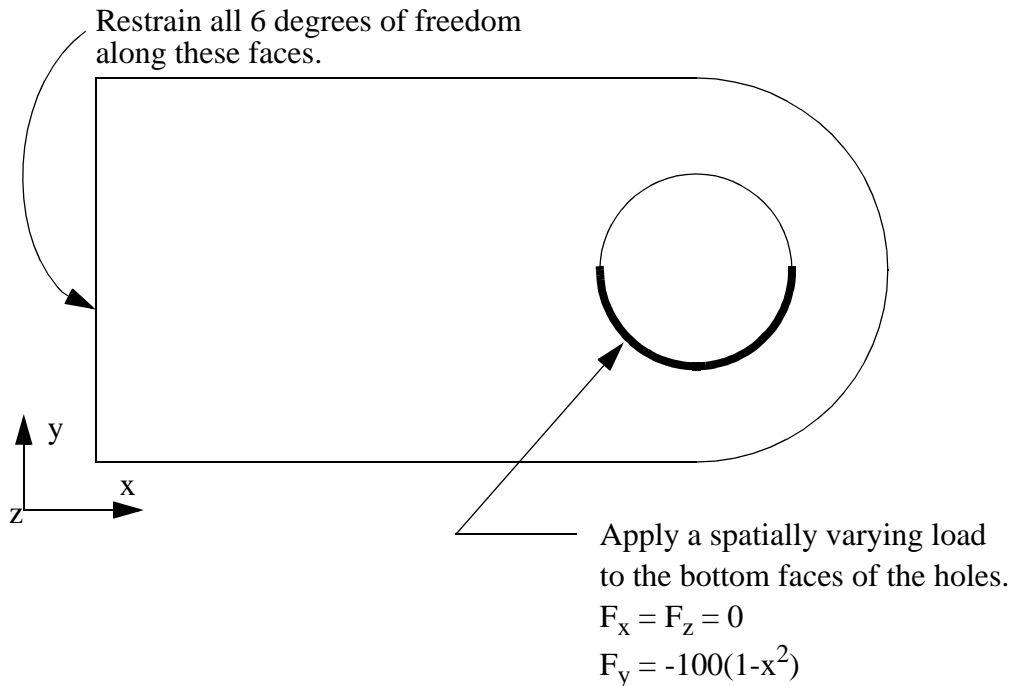
**Figure 10-1****Suggested Exercise Steps:**

- Open the database, **Clevis.db**.
- Create a spatially varying vector field named **Quadratic_load**, using the vector components described in the figure above.
- Create a nodal displacement boundary condition named **Clamped**, which restrains all degrees of freedom. Apply it to the geometry faces shown in the figure above.
- Create a force boundary condition named **Vertical_load**, which uses the **Quadratic_load** field. Apply it to the solid faces along the bottom half of the holes.
- Display both the displacement and force on the finite element model.

Exercise Procedure:

1. Open the database, **Clevis.db**.

File/Open Database...

Existing Database Name

Clevis.db

OK

2. Create a spatially varying vector field named **Quadratic_load**, using the vector components described in Figure 10-1.

◆ Fields

Action:

Create

Object:

Spatial

Method:

PCL Function

Field Name

quadratic_load

Field Type

◆ Vector

To define the *Vector Function* ('X','Y','Z'), click in the *Second Component* databox, and type the equation for the load as shown below. Remember to precede the independent variable, capital X, with a single quote.

-100*(1-'X2)**

Second Component

-100*(1-'X**2)

Apply

3. Create a nodal displacement boundary condition named **clamped**, which restrains all degrees of freedom. Apply it to the geometry faces shown in Figure 10-1.

◆ Loads/BCs

Action:

Create

Object:

Displacement

Type:

Nodal

New Set Name

clamped

Input Data...

Fields to Define a Spatially Varying Load

Applying Constraints

Translations <T1 T2 T3>

<0, 0, 0>

Rotations <R1 R2 R3>

<0, 0, 0>

OK

Select Application Region...

Geometry Filter

◆ Geometry

Select Geometry Entities

Select the left side of the model as shown below

To prepare for the application of loads and boundary conditions, you need to orient the model to facilitate cursor picking. Click on the **Front View** icon from the *Main Form*, then select the **Surface** icon from the *Select Menu*.



Front View



Surface

Use the rectangle selection technique (click and drag) to choose the application region for the constraint. Make sure that your *Picking Preference* is set to **Enclose Entire Entity**.

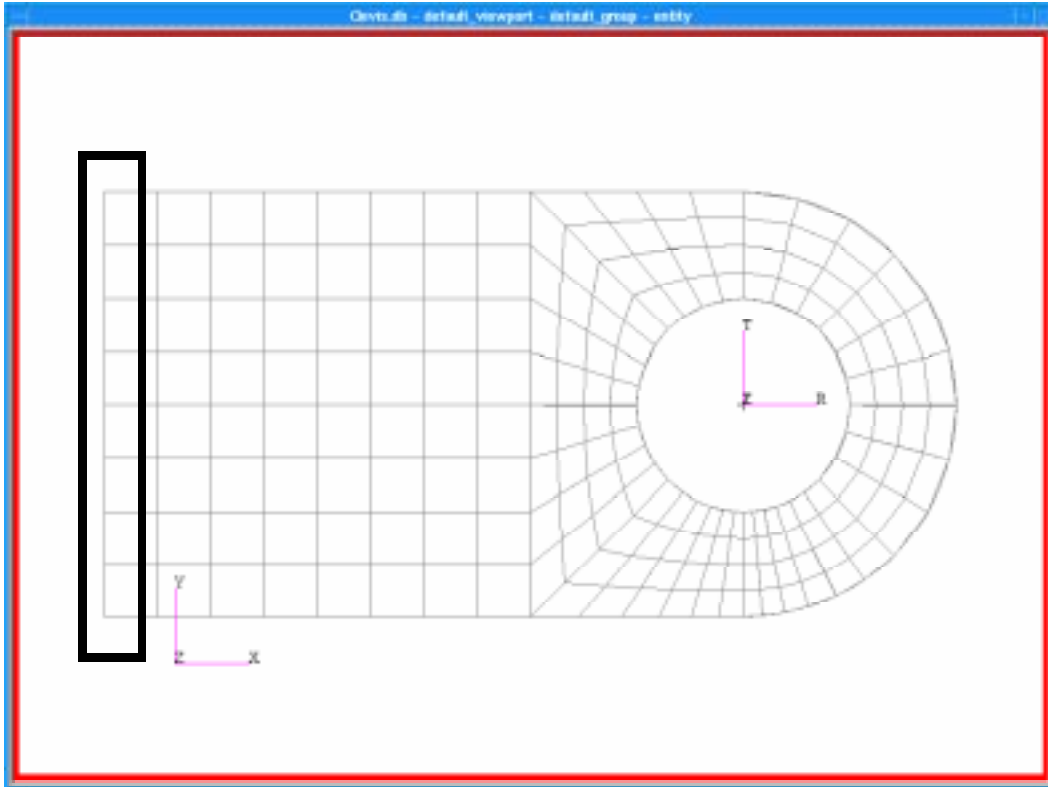

Add

OK

Apply

Vectors showing the constraints will be displayed at the display lines of the solid. If display lines are set to zero, the vectors will appear at the corners of the solid. To remove the vectors click on the Reset Graphics icon in the toolbar.



To redisplay vectors:

Action:

Plot Markers

Assigned Load/BC Sets

Displ-clamped

Select Groups

default_group

Apply

Vectors indicating constraints in translations and rotations will reappear at the solid's display lines.

4. Create an applied load named **Vertical_load**, which uses the **Quadratic_load** field. Apply it to the solid faces along the bottom half of the holes.

Action:

Create

Object:

Force

Type:

Nodal

New Set Name

vertical_load

Input Data...

Force <F1 F2 F3>

f:quadratic_load

In the *Force <F1 F2 F3>* databox, move the cursor down to the *Spatial Fields* listbox, and select **quadratic_load**.

OK

Select Application Region...

Applying a Spatially Varying Load

Geometry Filter◆ **Geometry**

Be sure that the **Surface** icon is still highlighted in the *Select Menu*. Click in the *Select Geometry Entities* databox, and select the surfaces for the load. Use the polygon pick method to select the solid faces that bound the bottom half of the holes, as shown in the figure below

**Polygon Picking**

You can select this icon or hold down **control** while dragging the cursor.

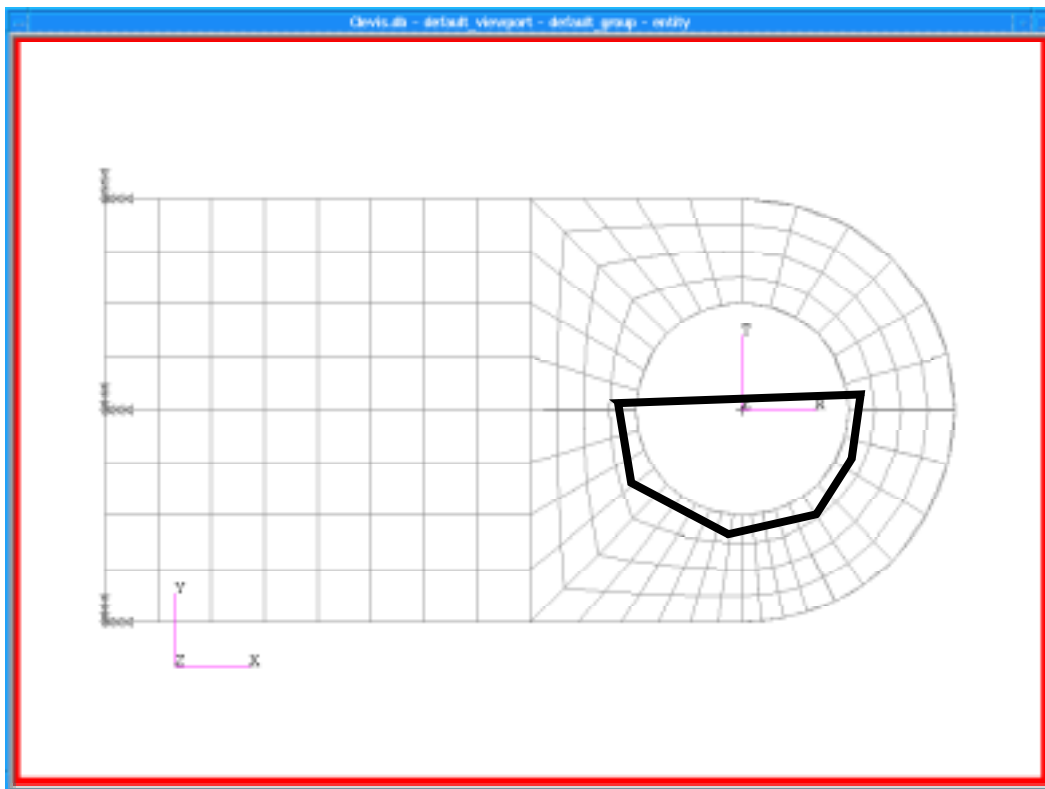
**Add****OK****Apply**

Vector markers indicating the applied load will appear as shown below. It's ok if your vectors from the clamped end are pointing in the opposite direction.

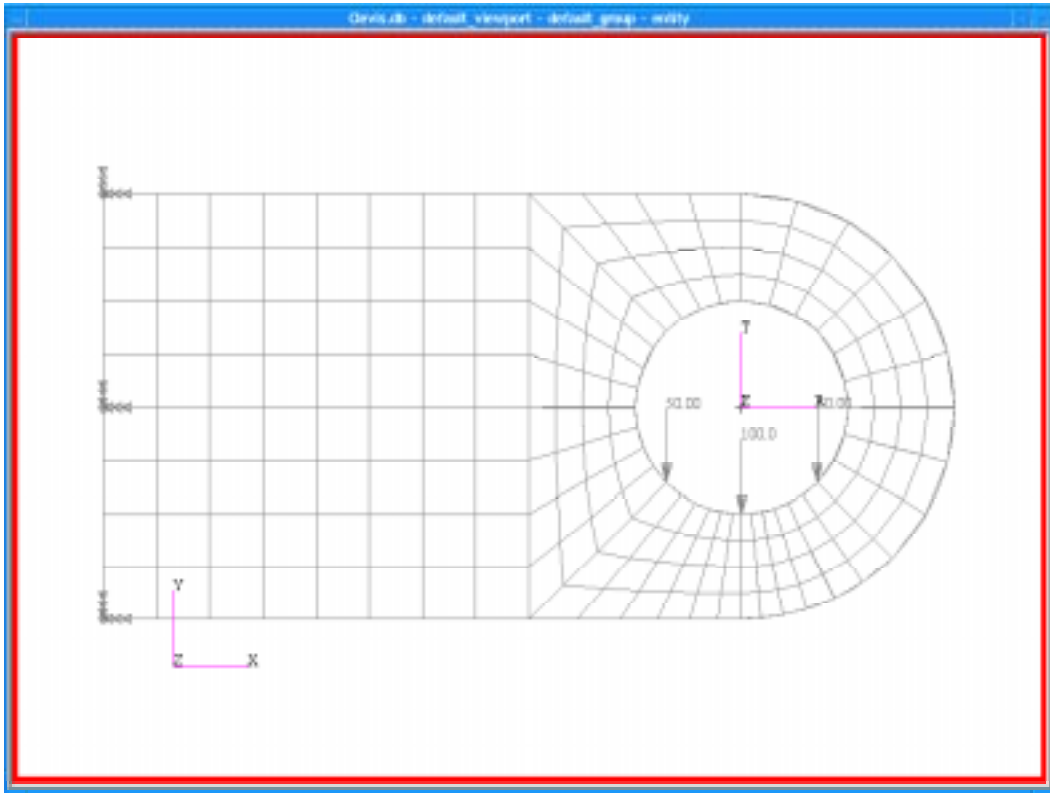

Display on FEM

5. Display both the displacement and force on the finite element model.

Display/Load/BC/Elem. Props...

Show on FEM Only

Apply

Cancel

In the *Load/Boundary Conditions* form, change the *Action* to **Plot Markers**.

Action:

Plot Markers

Assigned Load/BC Sets

Displ_clamped
Force_vertical_load

Select Groups

default_group

Apply

The loads and constraints should now be displayed at the nodal locations as shown below (orientation of the constraint arrows may vary).

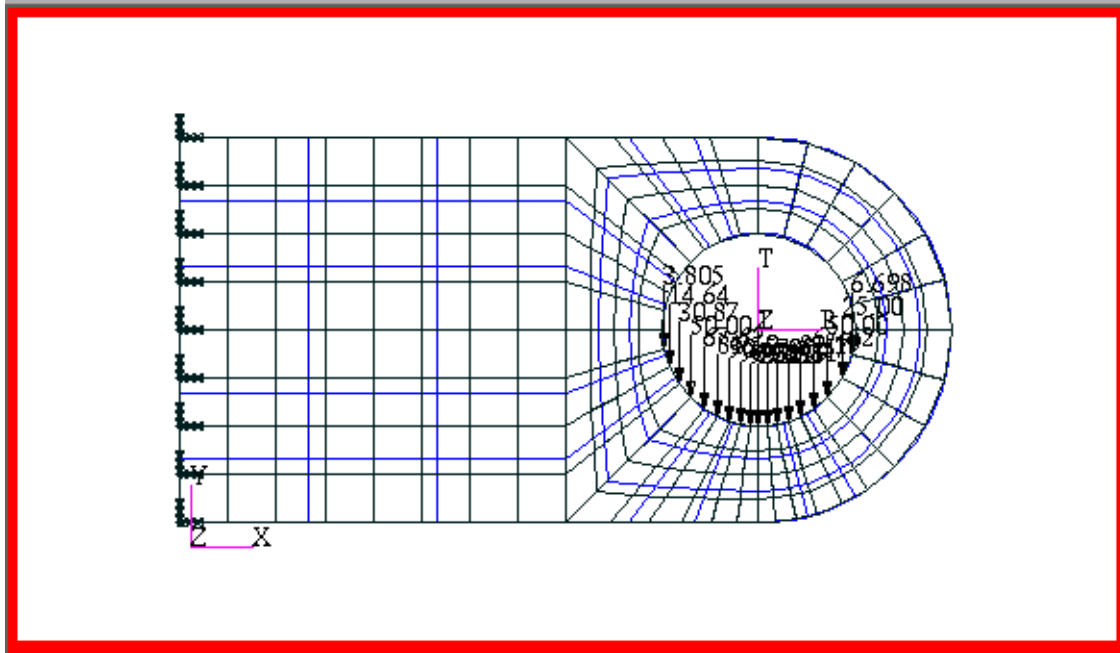

To turn off the values, use

Display/Load/BC/El. Props...

Vectors/Filters...

Show LBC/El. Prop. Values

Apply

To see the vectors scaled to the values, go to

◆ **Scaled - Model Relative**

Apply

Cancel

File/Quit

**Labels on
Vectors**

