

## LESSON 7

# *Finite Element Model of a 3-D Clevis*

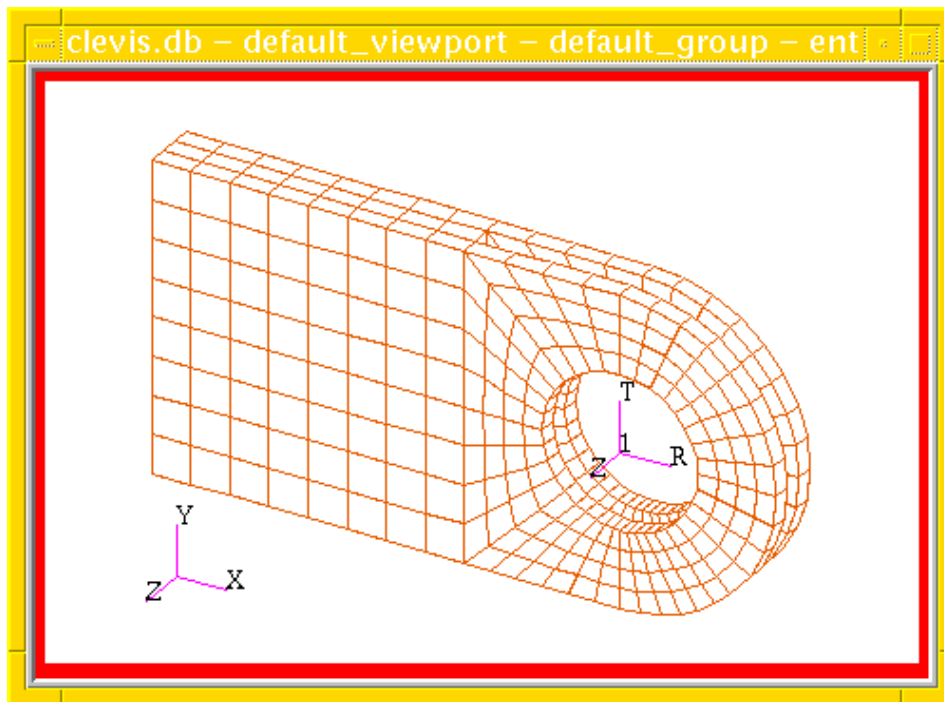

### **Objectives:**

- Apply a nonuniform mesh seed near a critical location of the model.
- Apply a global mesh to the seeded model.



## Model Description:

In this exercise you will define a finite element mesh for the Clevis model you developed earlier. You will use mesh seeding to create a refined mesh with a higher mesh density near the bottom of the hole where you will apply a force load in a future exercise.

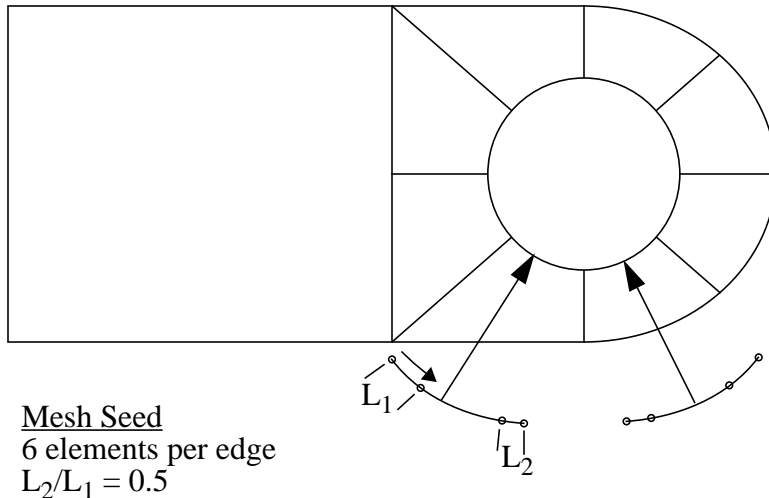

**Figure 7-1**

## Suggested Exercise Steps:

- Start MSCPATRAN and open the database **Clevis.db**.
- Using an isometric view of your model, zoom in on the lower half of the clevis hole. Save this view as a named view. Use the name **zoom\_in**.
- To further simplify the rendering of your clevis model you will now turn off the display lines so only the model's boundaries are shown.
- Create the mesh seeds needed to increase the mesh density in the area where the distributed load will be applied.
- Create a finite element mesh using the element topology and size listed in the diagram above.

---

## Exercise Procedure:

1. Start MSC/PATRAN and open the database **Clevis.db**.

### File/Open Database...

*Existing Database Name*

**Clevis.db**

**OK**

2. Using an isometric view of your model, zoom in on the lower half of the clevis hole. Save this view as a named view. Use the name **zoom\_in**.

There are two ways to get an isometric view of your model. The first is to click on the **isometric view** icon in the toolbar and the second is under **Viewing** on the Main Menu bar.



### Viewing/Named View Options...

*Select Named View*

**isometric\_view**

**Close**

### Viewing/Select Corners

When the cursor changes to a plus sign (+) select the lower half of the front clevis hole, as shown in the figure below, by clicking on a corner of the desired view rectangle (remember, click and hold down the left

---

**Create a  
Named View**

mouse button), and dragging the mouse cursor to the position of the diagonally opposite corner of the view rectangle. Releasing the left mouse button gives the new view.

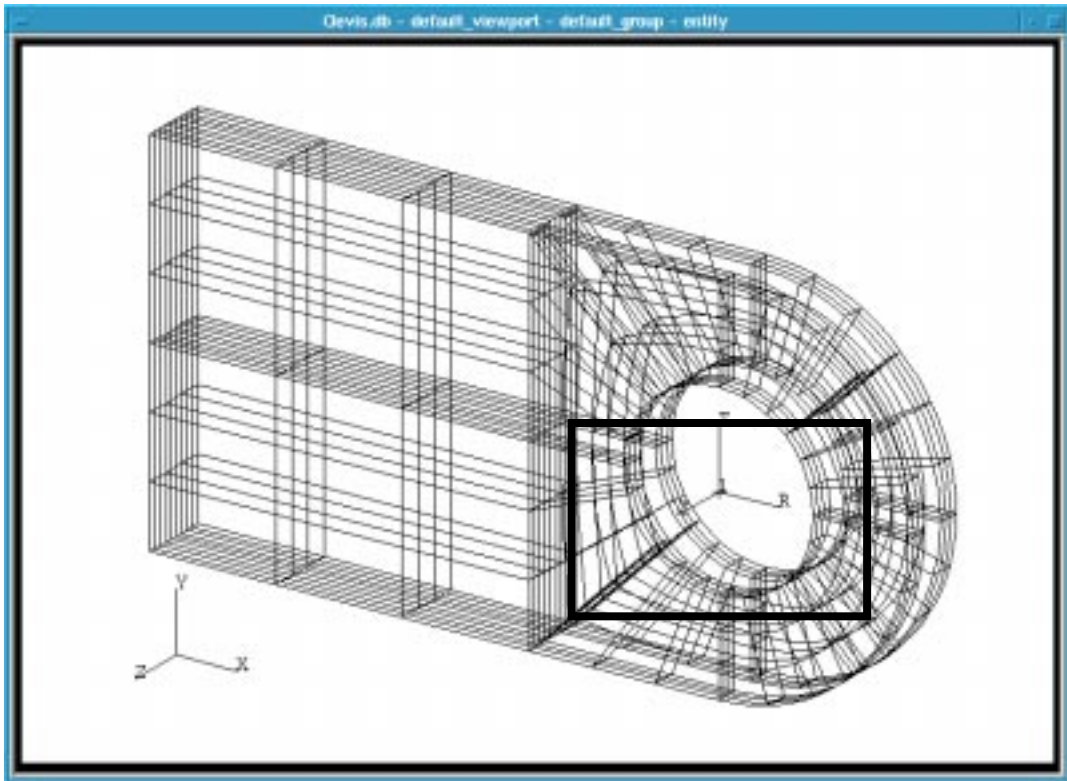

Since you will need this view in a future exercise, save it by creating a named view of the model's current orientation.

#### **Viewing/Named View Options...**

**Create View...**

*Create New View*

**zoom\_in**

**Apply**

The *Named View Options* form will now list your new saved view. Click on the scroll bar down arrow of the *Select Named View* listbox to display your new view then close the form.

**Close**

## Create a Nonuniform Mesh Seed

3. Create the mesh seeds needed to increase the mesh density in the area where the distributed load will be applied, as shown in the figure below.

### ◆ Finite Elements

Action:

Create

Object:

Mesh Seed

Type:

One Way Bias

### Num Elems and L2/L1

This selection allows you to specify the number of elements and their varying size along an edge of an entity. The symbol **L2/L1** represents the ratio of the length of the last element to that of the first element along the edge. The directionality of the edges is shown by the cyan arrows that appear on the model when you enter this form.

Number =

6

L2/L1 =

2

Curve List

See figure below

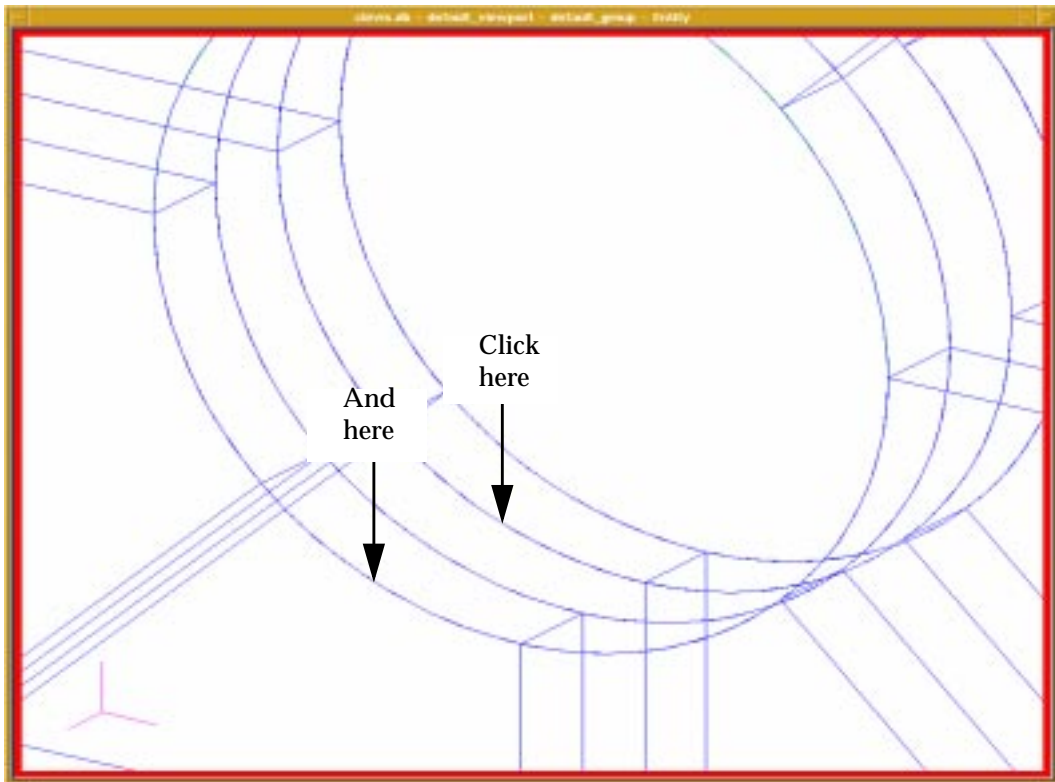

Next, you will select the adjacent edges shown in the following figure. Before you select the edges notice that the directionality of these edges is the same as that of the edges just selected. To obtain a symmetric mesh seed about the lowest point of the hole you must invert the *L2/L1* ratio, by changing its current value to **0.5** (or **-2**). Change the value, select the two edges, and click on **Apply**.

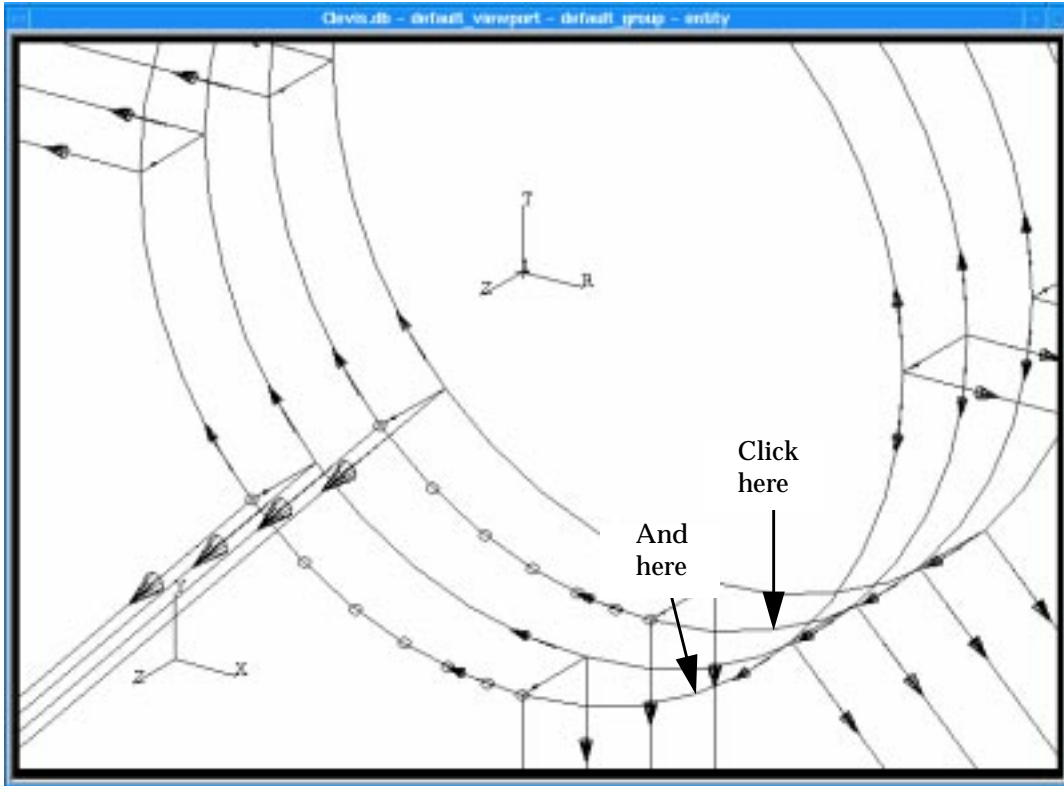

Before creating the model's finite element mesh, zoom out so you can see the entire model.

Click on **Viewing** in the *Main Form* and select **Fit View** from the pull-down menu or click on the **Fit View** icon.



4. Create a finite element mesh using the element topology and size listed below.

Action:

**Create**

Object:

**Mesh**

Type:

**Solid**

**Mesh the Model**

*Global Edge Length*

**0.5**

*Solid List*

Select All in Viewport

**Apply**

Your clevis model should look like the one shown below.

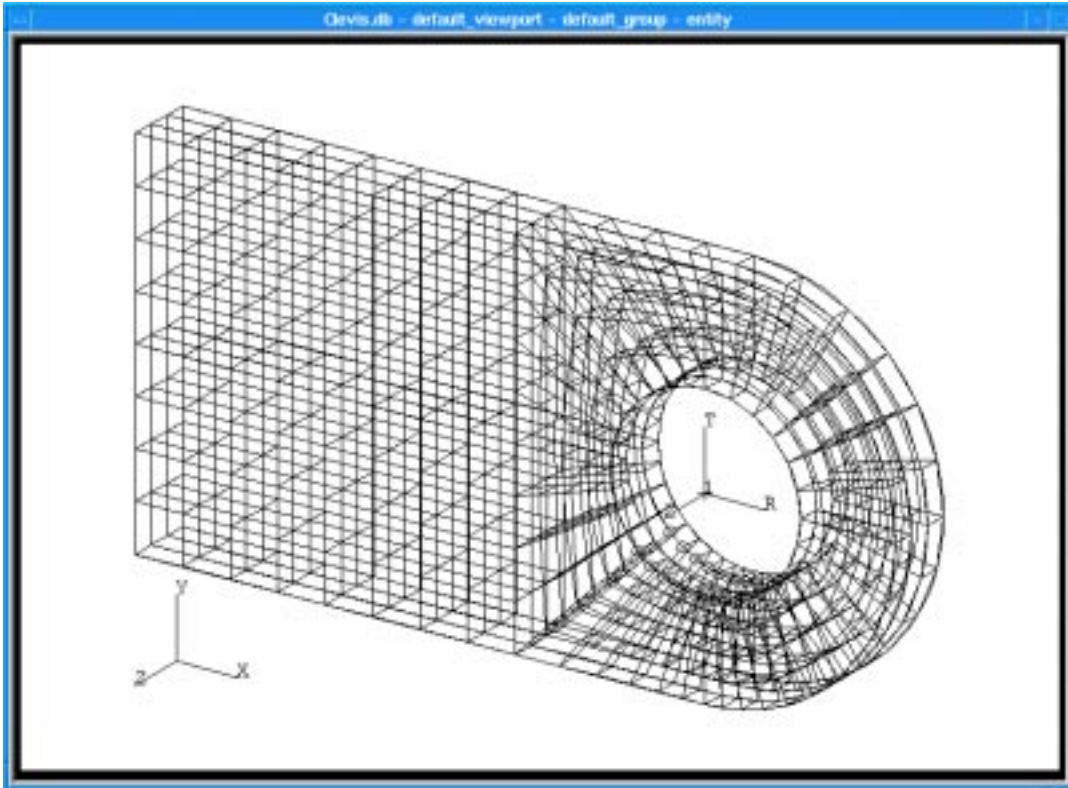

**File/Close**